

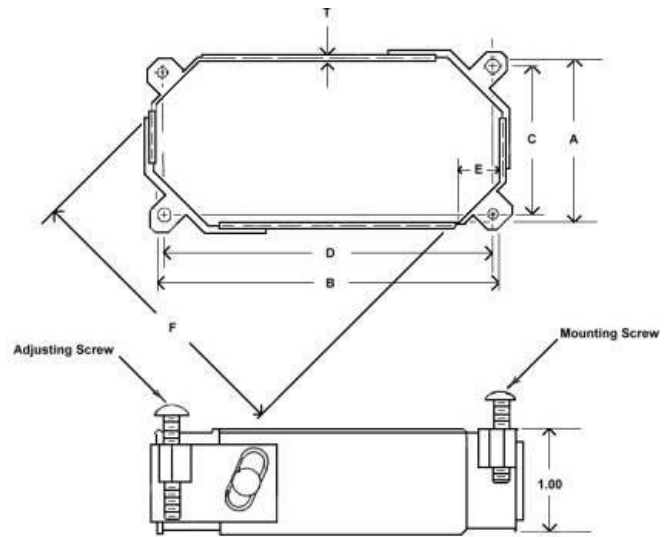

Avionics Mounting Devices

ARINC 408A Horizontal Scale Clamps 1" Deep



AMI P/N	Equivalent P/N	ARINC # 408 SPEC	A	B	C	D	E	F	T	MOUNTING SCREW	ADJUSTING SCREW	FINISH
			±.015	±.015	±.005	±.005	±.010	REF.	±.003			
3911000	64321B, 18671, MGB68247, NH1000433, 5340-01-107-6541	1.5X3A TI-R	1.457	3.175	1.340	3.060	.428	2.670	.045	MS24693BB30	MS35214-31	Note 1
3911001	NSA934901-06	1.5X3A TI-R	1.457	3.175	1.340	3.060	.428	2.670	.045	MS24693BB32	MS35214-115	Note 2
3911010	64419B, 5340-01-438-0430, MGB68568, 5340-01-332-5439, 7001995-1	1.5X3A TI-R	1.457	3.175	1.340	3.060	.428	2.670	.045	MS35214-29	MS35214-46	Note 1
3911050	64470	1.5X3A TI-R	1.457	3.175	1.340	3.060	.428	2.670	.045	MS35214-29	MS35214-46	Notes 1 & 4
3912000	64676B	1.5X3A TI-R	1.457	3.175	1.340	3.060	.428	2.670	.045	MS24693BB30	MS35214-31	Note 3
3912005	64641B	1.5X3A TI-R	1.457	3.175	1.340	3.060	.428	2.670	.045	MS35214-29	MS35214-46	Note 3

Notes:
 1: Anodized per MIL-A-8625, Type 2, Class 1, Clear.
 2: Anodized per MIL-A-8625, Type 1, Class 1, Clear.
 3: Chem-filmed per MIL-DTL-5541, Type 1, Class 1A, Yellow.
 4: Chem Film per MIL-DTL-5541, Type 2, Class 3, Clear
 5 Closing brackets are self-locking
 Recommended mounting and adjusting screw torque is 5-8 in. lb.
 All clamps are designed to meet the requirements of MIL-C-6818 and/or customer requirements.
 Band and closing bracket materials are 6061-T6 per QQ-A-200/8, or AQMS-QQ-A-250/11.
 Rivet materials are 2017 per QQ-A-225/5

ARINC Horizontal Scale Clamps 2" Deep

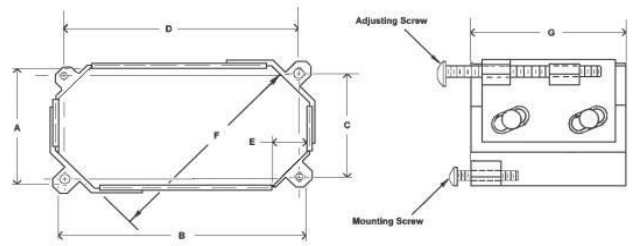

AMI P/N	Equivalent P/N	ARINC# 408 SPEC	A	B	C	D	E	F	G	T	MOUNTING SCREW	ADJUSTING SCREW	Notes
			±.015	±.015	±.005	±.005	±.010	REF.	±.03	±.003			
3921000	64481B, 5340-01-504-6662, NSA934901-17, 544104	1.5X3AT I-R	1.457	3.175	1.340	3.060	.428	2.670	2.000	.045	MS35214-29	MS35214-50	Note 1
3922000		1.5X3AT I-R	1.457	3.175	1.340	3.060	.428	2.670	2.000	0.045	MS35214-29	MS35214-50	Note 3

Notes:
 1: Anodized per MIL-A-8625, Type 2, Class 1, Clear.
 2: Anodized per MIL-A-8625, Type 1, Class 1, Clear.
 3: Chem-filmed per MIL-DTL-5541, Type 1, Class 1A, Yellow.
 4: Chem Film per MIL-DTL-5541, Type 2, Class 3, Clear
 5 Closing brackets are self-locking
 Recommended mounting and adjusting screw torque is 6-10 in. lb.
 All clamps are designed to meet the requirements of MIL-C-6818 and/or customer requirements.
 Band and closing bracket materials are 6061-T6 per QQ-A-200/8, or AQMS-QQ-A-250/11.
 Rivet materials are 2017 per QQ-A-225/5